

CERTIFICATIONS

All safety relief valves manufactured by COI TECHNOLOGY strictly conform with the regulations set forth by " CE Direct. 97/23/CE " as issued in June 2002 and are consequently approved and specifically marked CE.

Testing procedures required to obtain official approval of COI TECHNOLOGY safety valves have been conducted in experimental plants set at the Milan University, (Politecnico of Milan) Italy, as well as in cooperation and supervision of the Inspector of the TUV Institute Germany.

All tests have confirmed the excellent performances of COI TECHNOLOGY safety valves which have also obtained additional confirmation of their superior flow coefficient in line with the company's long standing reputed technical standards.

APPROVALS: UNI EN 9001:2000, PED/97/23/CE, ATEX94/9/CE, TUV

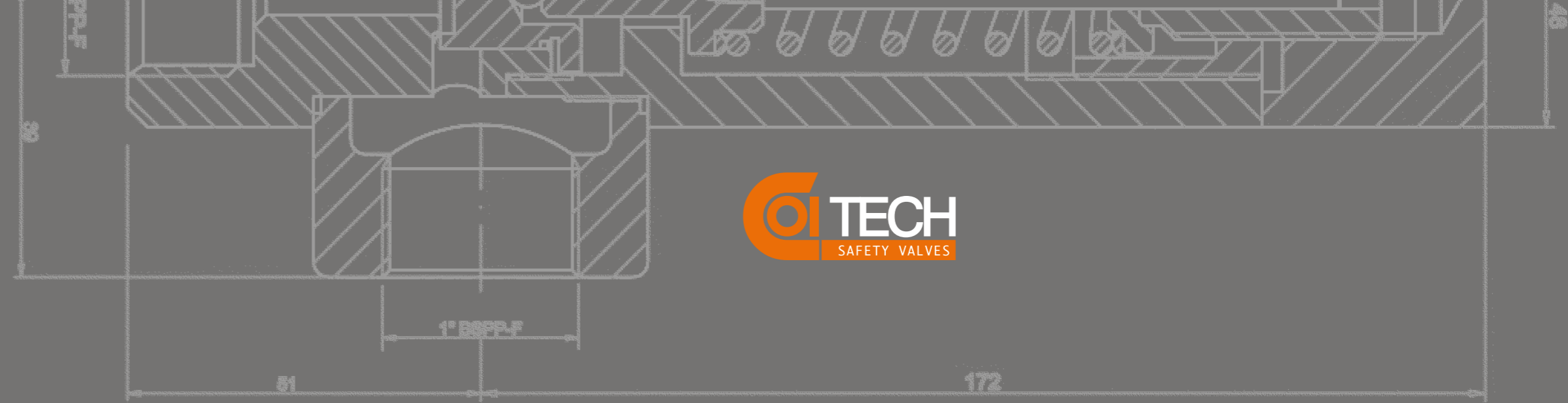

Coi Technology S.r.l.
Via Marconi, 37/41
20089 Rozzano (MI)
Tel. +39 02 57501557
Fax +39 02 57501578
E-mail: info@coitech.it
www.coitech.it

www.lacentraldesign.it

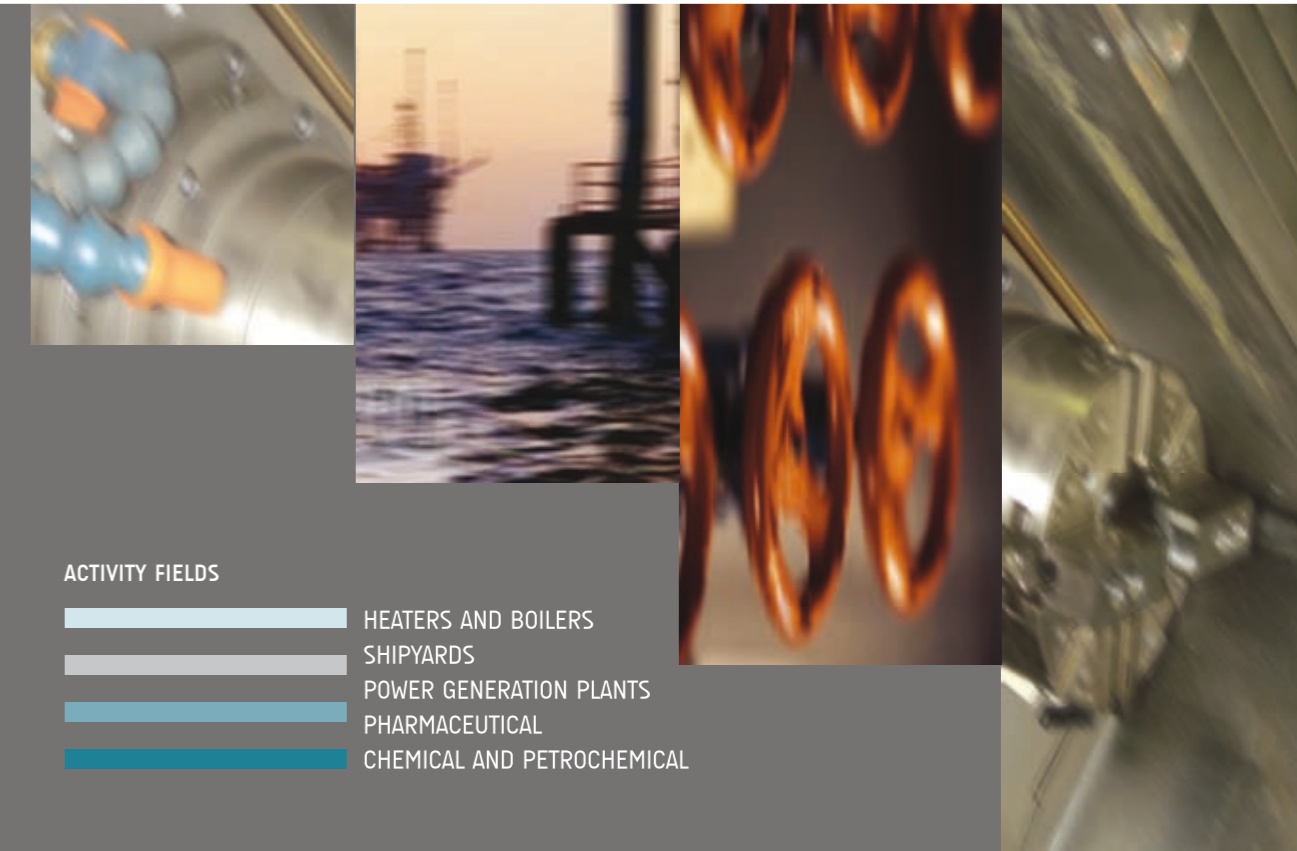

ACTIVITY FIELDS

- HEATERS AND BOILERS
- SHIPYARDS
- POWER GENERATION PLANTS
- PHARMACEUTICAL
- CHEMICAL AND PETROCHEMICAL



COMPANY

COI TECHNOLOGY has been operating for the past forty years in the field of safety relief valves. The Company is particularly specialized in designing and manufacturing of high and low pressure safety relief valves for gas, steam and liquid service.



COI TECHNOLOGY safety relief valves are normally used for the protection of chemical and pharmaceutical plants, steam boilers and fire-protection sites, cryogenics installations, methane and compressed air plants, cold-storage, refrigerating and thermal compressors units, hydroelectric and/or steam-generating stations, water supply engineering and water treatments in general, liquid and oenological dosages.

COI TECHNOLOGY accepted high quality standards and its long lasting and successful technical experience in Italy and overseas are placed at the customers' disposal for the solution of problems related to specific requirements and needs.

The Company's workshops are technologically advanced and are equipped with the most advanced number and tape-controlled machinery to manufacture particular items in steel, bronze, brass and different special materials such as duplex, hastelloy, titanium, incolloy, monel and plastic materials like PVC, PTFE and PP with a reputation for innovation, sophistication and superior quality.

PRODUCTION RANGE

Safety relief valves

Relief valves

Safety valves for cryogenics

Free exhaust safety valves

Flanged safety relief valves (ANSI, DIN)

Change over valves

MAINTENANCE OF SAFETY RELIEF VALVES

Highly qualified expert technical after-sale assistance is assured to meet specific and/or emergency requirements.

Design and manufacture operations are aimed at solving all real problems directly connected with plant engineering, maintenance and general performance.



Safety valves for compressed air and inert gases

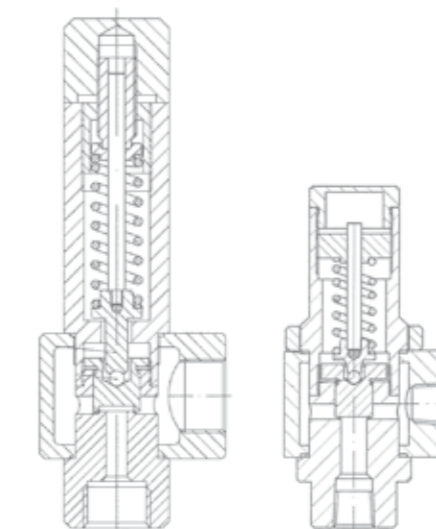

Safety relief valve for gas and liquid service (high pressure)